

# 330 IK US

**NBI**   
**MANCONI**

Semi-Automatic Gravity Feed Slicer

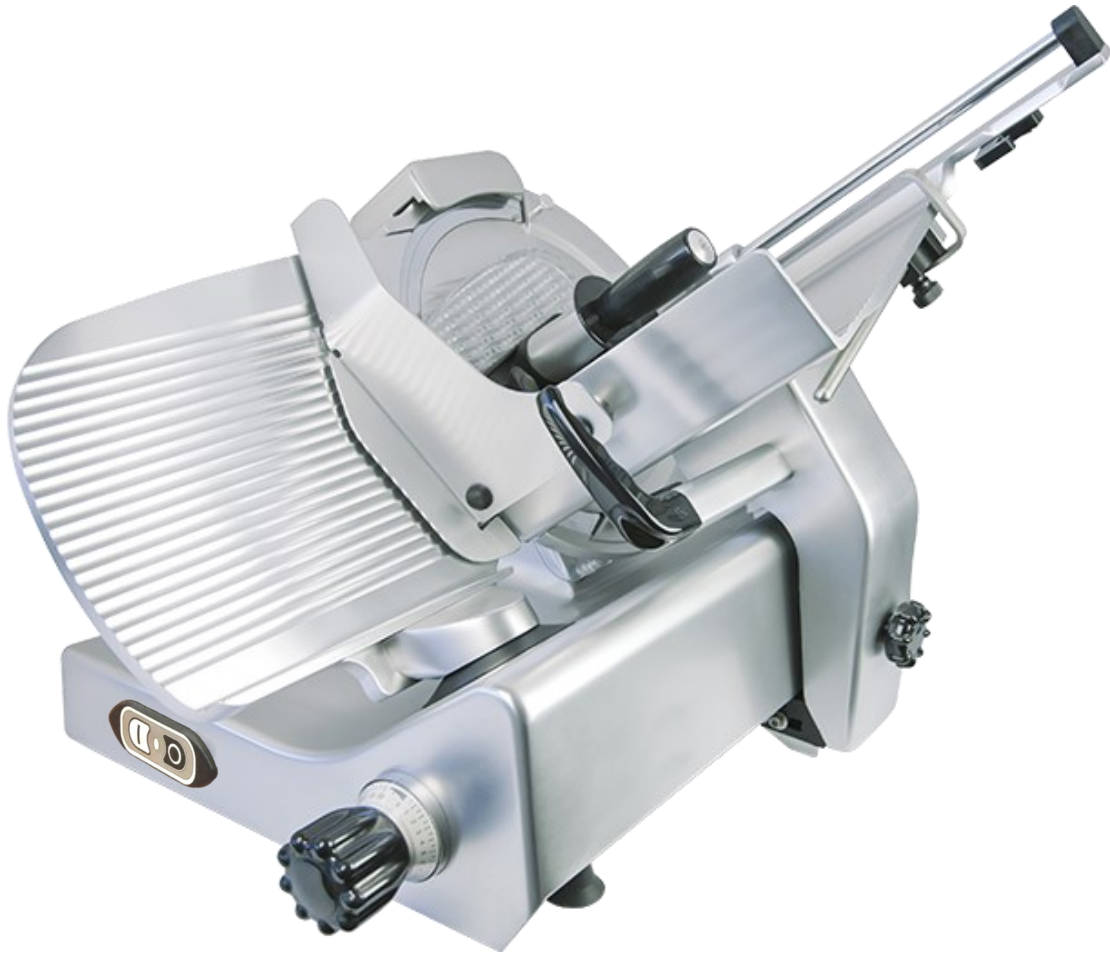

- Gear driven motor
- 13" blade diameter
- Integrated knife Sharpener
- Integral motor overload protection
- Electrical protection IPX3
- Ergonomic operating height

**Retail Scales, Automatic Wrapping Systems & Slicers**  
**NEW BRUNSWICK INTERNATIONAL, INC.**

## Features

- 13" Semi -Automatic slicer
- Durable long lasting finish
- Precision slicing mechanism minimizing waste
- Integrated knife Sharpener
- Blade with enhanced cutting sections
- Integral motor overload protection
- Easy to load (low loading height); reduces operator strain.
- Operator safety & cleaner working area
- Sharpened remnant holder removable, easy to clean saves time
- Carriage with spiked and swinging remnant holder
- Reduced foot counter space deflector for easy cleaning
- Perfect slip grooves for a more performing sliding movement
- Adjustable food fence
- Self-locking clamping device

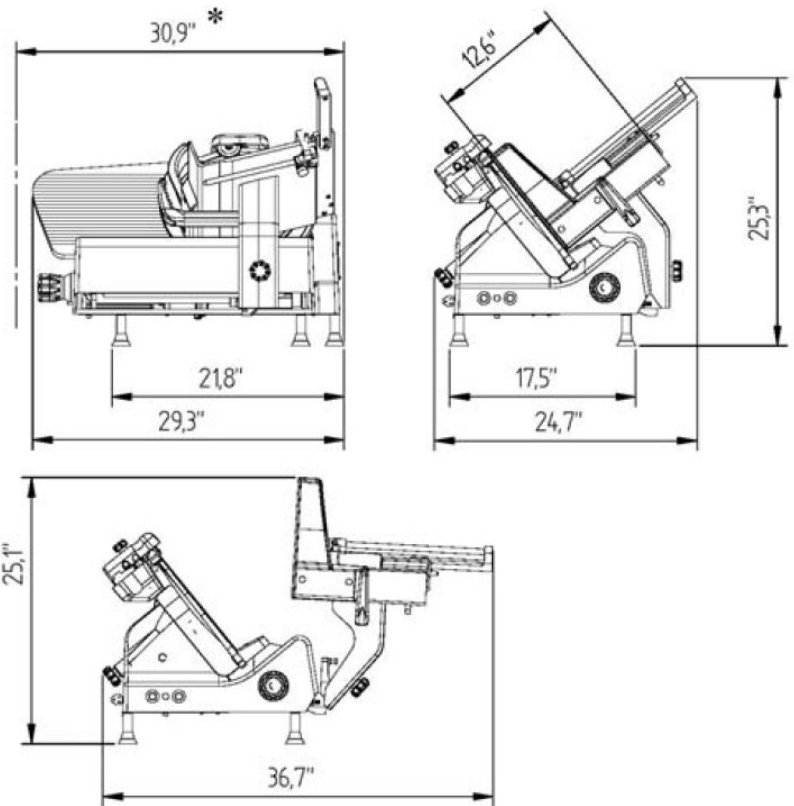

\* Overall measurements with product holder at the end of its stroke



### Technical Features- 330 IX SA US Specifications

Overall Dimensions	23.9 x 20 x 18.9in
Horsepower	Gear driven motor
Blade diameter	13" dia
Blade speed	255 rpm
Slice thickness	0 to .94 in
Electrical Protection	IPX3 (Motor IPX5)
Net weight	106 lbs
Electrical Specifications	120V/60Hz /360W a.c. Monophase
Cutting Capacity	Ø 240 mm - □290 x 210mm

## New Brunswick International, Inc.



**Corporate Headquarters**  
 76 Veronica Ave  
 Somerset, NJ 08873  
 TEL: (732) 828-3633  
 FAX: (732) 828-4884

**West Coast Office**  
 530 West Central Ave. Suite C  
 Brea, CA 92821  
 TEL: (714) 671-7911  
 Fax: (714) 671-0798

[www.nbidigi.com](http://www.nbidigi.com)